

MODEL

FLF200PM is a non-refrigerated, semi-recessed stainless steel drinking fountain for direct connection to a cold water supply or for use with remote water chillers.

STANDARD FEATURES

- Waterways Are Lead-Free In Materials & Construction
- Single Push Button Keeps Water Flowing While Button Is Depressed
- Built-In Pressure Regulator Assures Smooth, Steady Water Flow
- Satin Finish Stainless Steel Top
- Bottom Cover Plate
- Limited 1-Year Warranty

INSTALLATION

- Prior to roughing-in, consult local, state, and federal codes for proper mounting height.
- Shipped with complete instructions.

COLORS

- Standard Cabinet Finish: Stainless Steel
- Optional finish at extra cost: Regency Bronze

NET WEIGHT: Approximately 13 Lbs.

Limited 1-Year Warranty (Continental limits of the United States and Canada): One year from date of installation on parts only. Detailed warranty certificate enclosed with each drinking fountain; sample copy available upon request.

Components in this drinking fountain are lead free as defined by the Safe Drinking Water Act Amendments of 1986, and the Lead Contamination Control Act of 1988.



Model covered by these specifications complies with all known Plumbing Codes. Certified by Canadian Standards Association.

DRINKING FOUNTAINS SEMI-RECESSED



Model FLF200PM Shown



Export Warranty: One year on component parts. Detailed warranty certificate enclosed with each drinking fountain, sample copy available upon request.

Specifications are subject to change without notice.

Copyright 1999 OASIS Corporation

Oasis® is a registered trademark of OASIS Corporation.

Model	Style	Physical Dimensions In Inches			Extended From Wall	Recessed Into Wall
		Height	Width	Depth		
FLF200PM	Semi-Recessed	27-3/4	17-5/16	13	9-1/2	3-1/2

CLASSWATER INC.

2600 John St., Unit 118
Markham, ON L3R 3W3

(905) 940-5800 Fax (905) 940-4642 888-CLASWTR(252-7987)

www.classwater.com

CLASSWATER INC.
 2600 John St., Unit 118
 Markham, ON L3R 3W3
 (905) 940-5800 Fax (905) 940-4642 888-CLASWTR(252-7987)
www.classwater.com

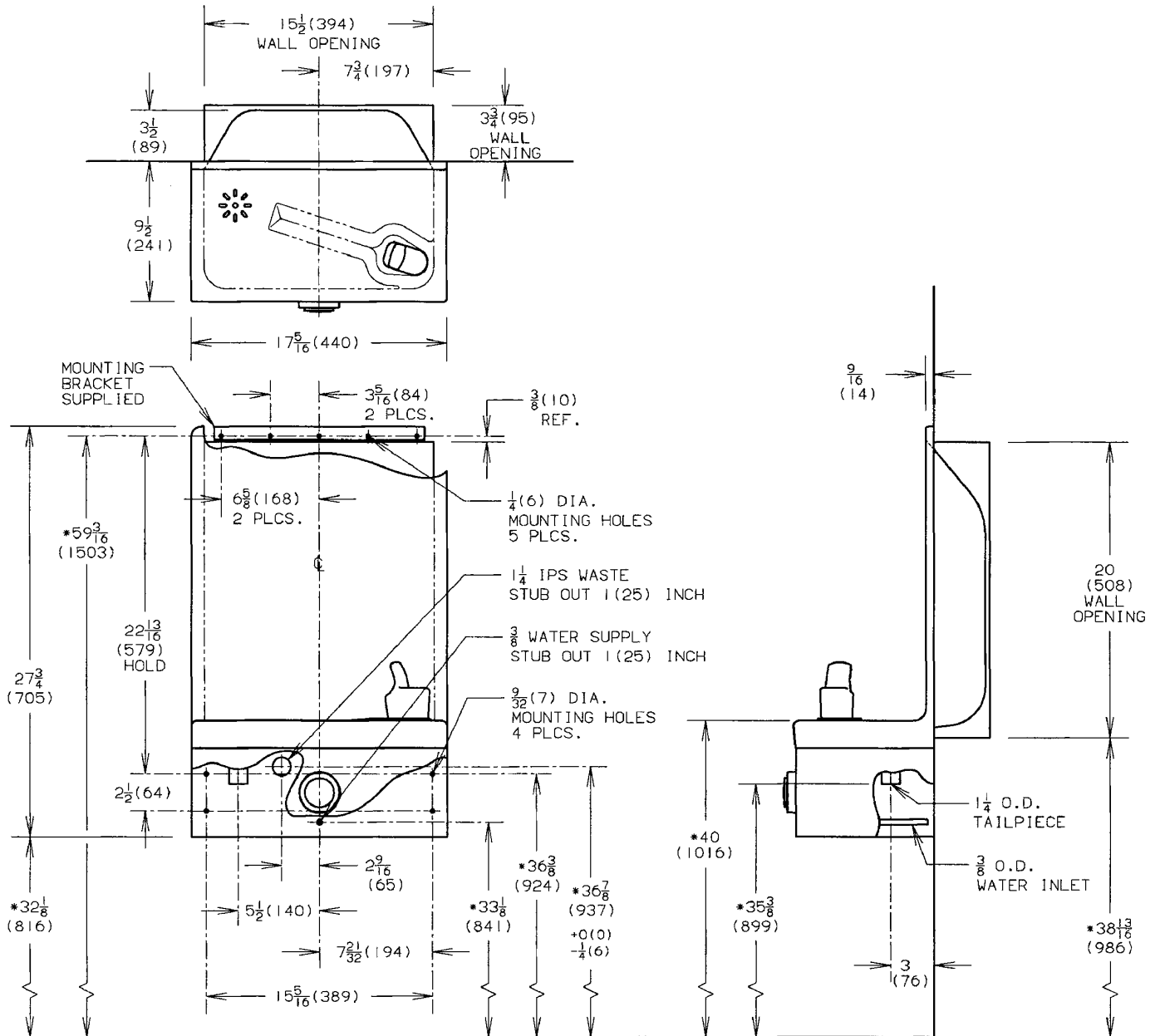

NOTES:

1. TRAP AND STOP VALVE NOT FURNISHED.
- *2. RECOMMENDED ADULT HEIGHT INSTALLATION SHOWN. ADJUST VERTICAL DIMENSIONS AS REQ'D TO COMPLY WITH FEDERAL, STATE & LOCAL CODES.
3. ALL DIMENSIONS ARE IN INCHES. DIMENSIONS IN PARENTHESES () ARE IN MILLIMETERS.

	<p>ROUGHING-IN AND DIMENSIONAL DRAWING</p>
--	----------------------------------------------------