

**MODEL**

FLF630PM is a non-refrigerated, stainless steel three station drinking fountain for direct connection to a cold water supply or for use with remote water chillers.

**STANDARD FEATURES**

- Waterways Are Lead-Free In Materials & Construction
- Button for each station activates the water flow for the respective fountain.
- Built-In Pressure Regulator Assures Smooth, Steady Water Flow
- Satin Finish Stainless Steel
- Bottom Cover Plate
- Limited 1-Year Warranty

**INSTALLATION**

- Prior to roughing-in, consult local, state, and federal codes.
- Shipped with complete instructions.

**COLOR**

Standard Cabinet Finish: Stainless Steel

**NET WEIGHT:** Approximately 67 Lbs.

**Limited 1-Year Warranty** (Continental limits of the United States and Canada): One year from date of installation on parts only. Detailed warranty certificate enclosed with each drinking fountain; sample copy available upon request.

Components in this drinking fountain are lead free as defined by the Safe Drinking Water Act Amendments of 1986, and the Lead Contamination Control Act of 1988.



Model covered by these specifications complies with all known Plumbing Codes. Certified by Canadian Standards Association.

**Export Warranty:** One year on component parts. Detailed warranty certificate enclosed with each drinking fountain, sample copy available upon request.



# DRINKING FOUNTAINS THREE STATION

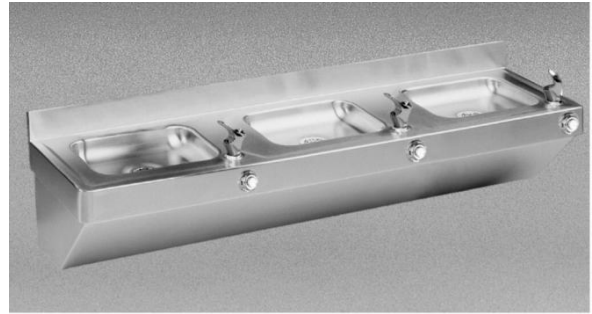

**Model FLF630PM Shown**

Specifications are subject to change without notice.

Copyright 1999 OASIS Corporation

Oasis® is a registered trademark of OASIS Corporation.

Model	Style	Physical Dimensions In Inches			Extended From Wall
		Height	Width	Depth	
FLF630PM	Three Station	13-1/2	54	15	15

## CLASSWATER INC.

2600 John St., Unit 118  
Markham, ON L3R 3W3

(905) 940-5800 Fax (905) 940-4642 888-CLASWTR( 252-7987)

[www.classwater.com](http://www.classwater.com)

**CLASSWATER INC.**  
 2600 John St., Unit 118  
 Markham, ON L3R 3W3  
 (905) 940-5800 Fax (905) 940-4642 888-CLASWTR( 252-7987)  
[www.classwater.com](http://www.classwater.com)

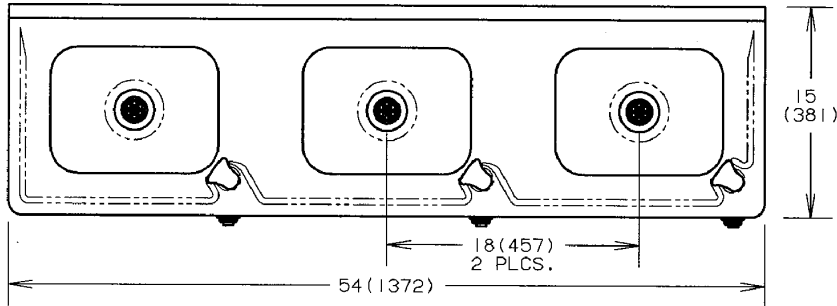

**INSTRUCTIONS:**

1. MOUNT WALL HANGERS WITH 1/4-14 X 1-3/4 SCREWS FURNISHED.
2. REMOVE SCREWS THAT FASTEN FOUNTAIN BOTTOM ENCLOSURE TO THE SINK APRON. SAVE SCREWS.
3. MOUNT SINK APRON ON WALL HANGERS. SECURE TO WALL WITH 1/4-14 X 1-3/4 SCREWS FURNISHED.
4. CONNECT "P" TRAP WASTE OUTLET TO 1-1/2" WASTE LINE.
5. FLUSH BUILDING WATER SUPPLY LINE BEFORE CONNECTING TO FOUNTAIN.
6. CONNECT COLD WATER SUPPLY TO 3/8 MALE FLARE WATER INLET.
7. TURN ON WATER SUPPLY AND CHECK FOR LEAKS.
8. REPLACE BOTTOM ENCLOSURE ON SINK APRON WITH SCREWS SAVED FROM STEP 2 ABOVE.
9. ALL DIMENSIONS ARE IN INCHES DIMENSIONS IN PARENTHESES ( ) ARE IN MILLIMETERS
- \* 10. RECOMMENDED ADULT HEIGHT INSTALLATION SHOWN. ADJUST VERTICAL DIMENSIONS AS REQ'D TO COMPLY WITH FEDERAL, STATE, AND LOCAL CODES.

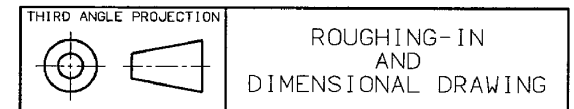
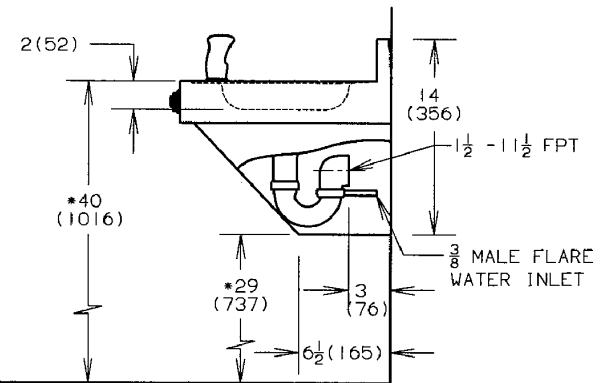
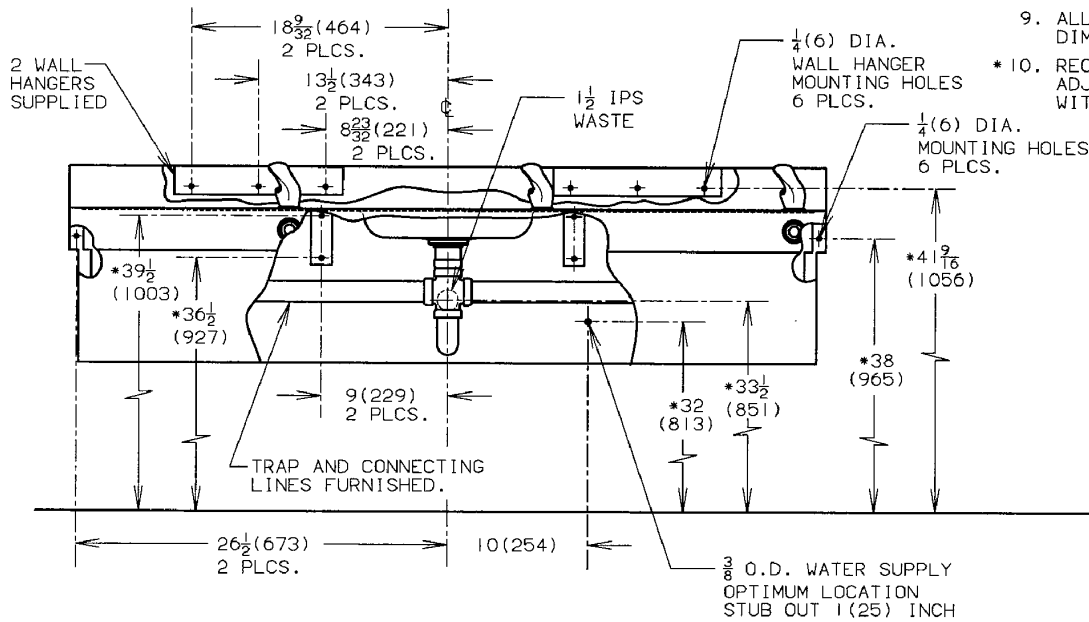

Oasis® is a registered trademark of OASIS Corporation  
 Specifications are subject to change without notice  
 Copyright 1999 OASIS Corporation