

Model

- ❑ M140PM is a non-refrigerated drinking fountain. When the push-button is depressed, water continues to flow as long as the button is depressed.

When this fountain is properly installed, it allows your facility to comply with ADA requirements.

Standard Features

- Waterways Are Lead-Free In Materials & Construction
- Stainless Steel Surfaces
- Flexible Bubbler Guard
- Heavy-Gauge Galvanized Steel Wall Mounting Frame
- Limited 1-Year Warranty

Installation

- Prior to roughing-in, consult with local, state, and federal codes for proper mounting height.
- Shipped with complete instructions and wall mounting frame.

Colors

- ❑ Standard Finish: Stainless Steel
- ❑ Optional finish at extra cost: Regency Bronze

Net Weight: Approximately 29 Lbs.

Limited 1-Year Warranty (Continental limits of the United States and Canada): One year from date of installation on parts only. Detailed warranty certificate enclosed with each drinking fountain; sample copy available upon request.

Components in this fountain are lead free as defined by the Safe Drinking Water Act Amendments of 1986, and the Lead Contamination Control Act of 1988.

DRINKING FOUNTAIN ♿ BARRIER-FREE MODULAR

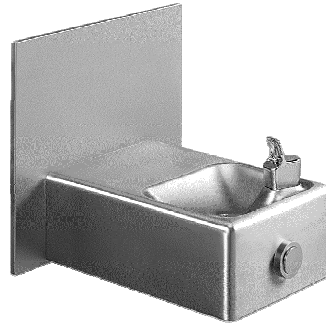

The distinctive, space-saving fountain serves the disabled as well as the able-bodied.



Model covered by this specification complies with all known Plumbing Codes. Certified by Canadian Standards Association.

Export Warranty: One-year on component parts. Detailed warrant certificate enclosed with each drinking fountain; sample copy available upon request.

CLASSWATER INC.
2600 John St., Unit 118
Markham, ON L3R 3W3
(905) 940-5800 Fax (905) 940-4642 888-CLASWTR(252-7987)
www.classwater.com

CLASSWATER INC.
 2600 John St., Unit 118
 Markham, ON L3R 3W3
 (905) 940-5800 Fax (905) 940-4642 888-CLASWTR(252-7987)
www.classwater.com

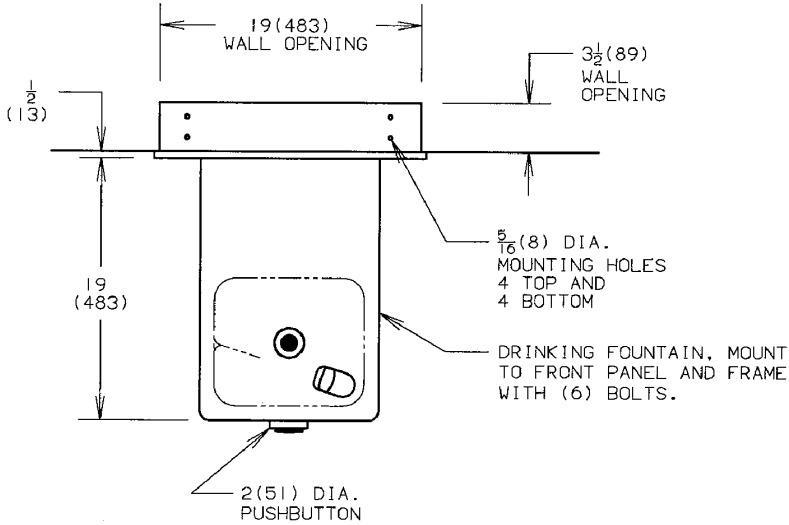

NOTES:

1. STOP VALVE NOT FURNISHED.
- *2. RECOMMENDED ADULT HEIGHT INSTALLATION SHOWN. ADJUST VERTICAL DIMENSIONS AS REQ'D TO COMPLY WITH FEDERAL, STATE, AND LOCAL CODES.
3. ALL DIMENSIONS ARE IN INCHES. DIMENSIONS IN PARENTHESES () ARE IN MILLIMETERS.

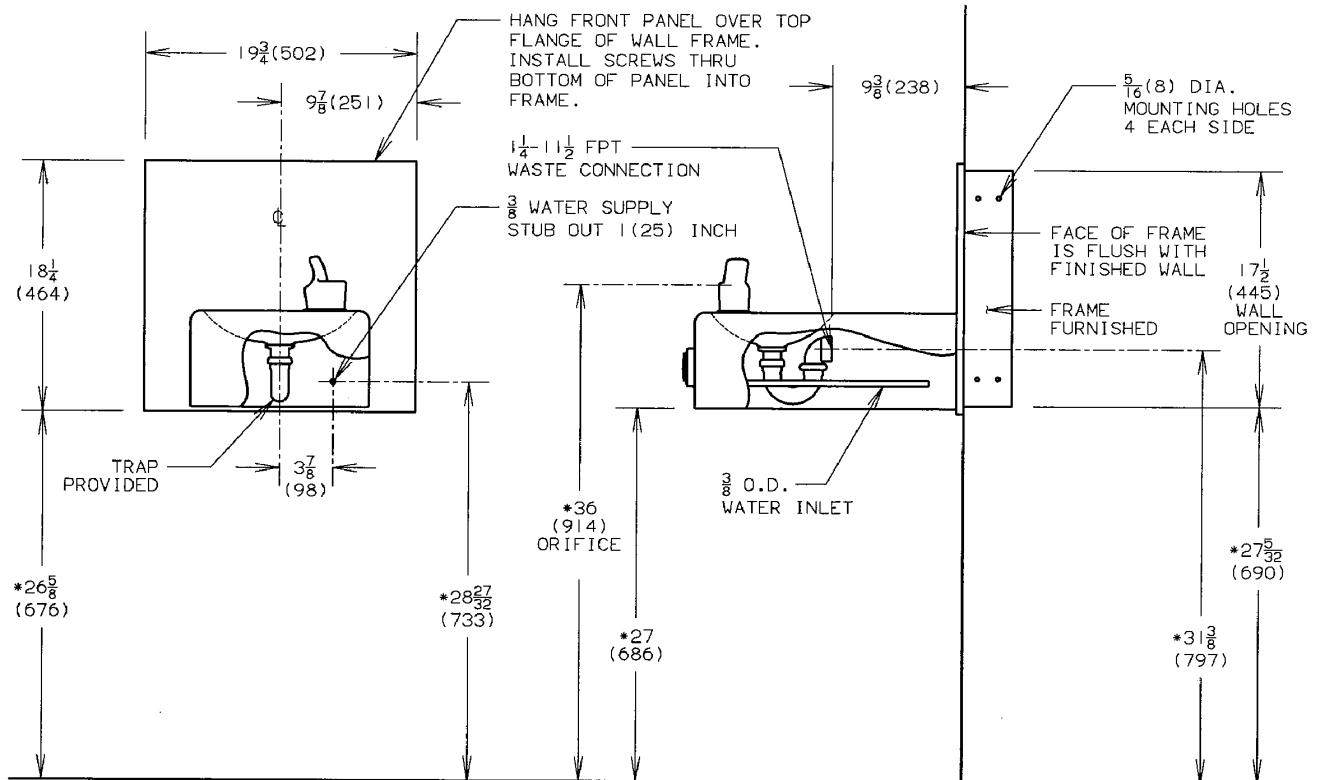

THIRD ANGLE PROJECTION	ROUGHING-IN AND DIMENSIONAL DRAWING
------------------------	-------------------------------------