

**Models**

- PLF8FA delivers 8 gph of chilled drinking water.
- PLF8FAH is a Hot 'N Cold and serves 45 cups of piping hot water, plus 8 gph of chilled drinking water.
- PLF14FA delivers 14 gph of chilled drinking water.
- PLF14FAH is a Hot 'N Cold and serves 45 cups of piping hot water, plus 14 gph of chilled drinking water.

**Standard Features**

- Waterways Are Lead-Free In Materials & Construction
- Stainless Steel Top
- Dial-A-Drink® Bubbler
- Flexible Bubbler Guard
- Heavy-Gauge Galvanized Structural Steel Frame
- Stainless Steel Wrap-Around Base Resists Corrosion
- High-Efficiency Cooling Tank and Coil
- Refrigerant R-134a
- Limited 5-Year Warranty

**Installation**

- Prior to roughing-in, consult with local, state, and federal codes.
- Shipped with complete instructions.

**Colors**

- Standard Cabinet Finish: Mocha Tan Acrylic Enamel
- Optional finishes at extra cost: Stainless Steel and Baked Enamel finishes
  - Specify Finish \_\_\_\_\_

**Accessories**

*Glass Fillers*

- Push Handle 029603-004
- Push Back 029603-005
- Push Down 029603-006
- Glass Filler Kit is required for Field Installation of the above glass fillers (except Models PLF8FAH AND PLF14FAH).

*Foot Pedal*

- Factory Installed On Special Request
- Kits Available for Field Installation

**Limited 5-Year Warranty** (Continental limits of the United States and Canada): Five years on the sealed refrigeration system and most component parts. Detailed warranty certificate enclosed with each water



## WATER COOLERS AGAINST-A-WALL OR FREE-STANDING



Plumbing connections are completely enclosed within the cabinet, permitting flush-to-wall installation that saves as much as 30% floor space and simplifies housekeeping.

**Model PLF8FA Shown**

cooler; sample copy available upon request.

Components in these water coolers/fountains are lead free as defined by the Safe Drinking Water Act Amendments of 1986, and the Lead Contamination Control Act of 1988.



Models covered by these specifications comply with all known Plumbing Codes. Listed by Underwriter's Laboratories. Certified by Canadian Standards Association, and Certified to Air Conditioning and Refrigeration Institute Standard 1010.



Indicates conformity to European Union Directives.

**Export Warranty:** One year on the sealed refrigeration system and most component parts. Four-year replacement contract on sealed refrigeration system. Detailed warranty certificate enclosed with each water cooler, sample copy available upon request.

Specifications are subject to change without notice.

Copyright 1999 OASIS Corporation

Oasis® and Dial-A-Drink® are registered trademarks of OASIS Corporation.

\*Air Conditioning and Refrigeration Institute Standard Rating Condition 80°F inlet water temperature.

\*\* Special export models available, operable on 220-240 volts, 50/60 Hz. UL, CSA and ARI certification not applicable.

\*\*\*Hot 'N Cold™ Model delivers 45 six-ounce cups of water per hour in addition to cold water.

Model	50°F Drinking Water 90°F Ambient Air Temperature*		Pre-Cooler	Hot 'N Cold Model	115 Volts, 60 Hz			Glass Filler Accessory Option	Cabinet Color Option	Net Weight (Approx.)
	Rated Capacity GPH	Base Rate GPH			Compr. HP	Full Load Amps	Rated Watts			
PLF8FA	8.0	8.0	No	No	1/5	4.6	320	Yes	Yes	94 Lbs.
PLF8FAH***	8.0	8.0	No	Yes	1/5	8.9	820	No	Yes	98 Lbs.
PLF14FA**	14.0	8.0	Yes	No	1/5	4.6	320	Yes	Yes	96 Lbs.
PLF14FAH***	14.0	8.0	Yes	Yes	1/5	8.9	820	No	Yes	99 Lbs.

**CLASSWATER INC.**

2600 John St., Unit 118  
Markham, ON L3R 3W3

(905) 940-5800 Fax (905) 940-4642 888-CLASWTR( 252-7987)

[www.classwater.com](http://www.classwater.com)

Oasis® is a registered trademark of OASIS Corporation  
 Specifications are subject to change without notice  
 Copyright 1999 OASIS Corporation

**CLASSWATER INC.**  
 2600 John St., Unit 118  
 Markham, ON L3R 3W3  
 (905) 940-5800 Fax (905) 940-4642 888-CLASWTR( 252-7987)  
[www.classwater.com](http://www.classwater.com)

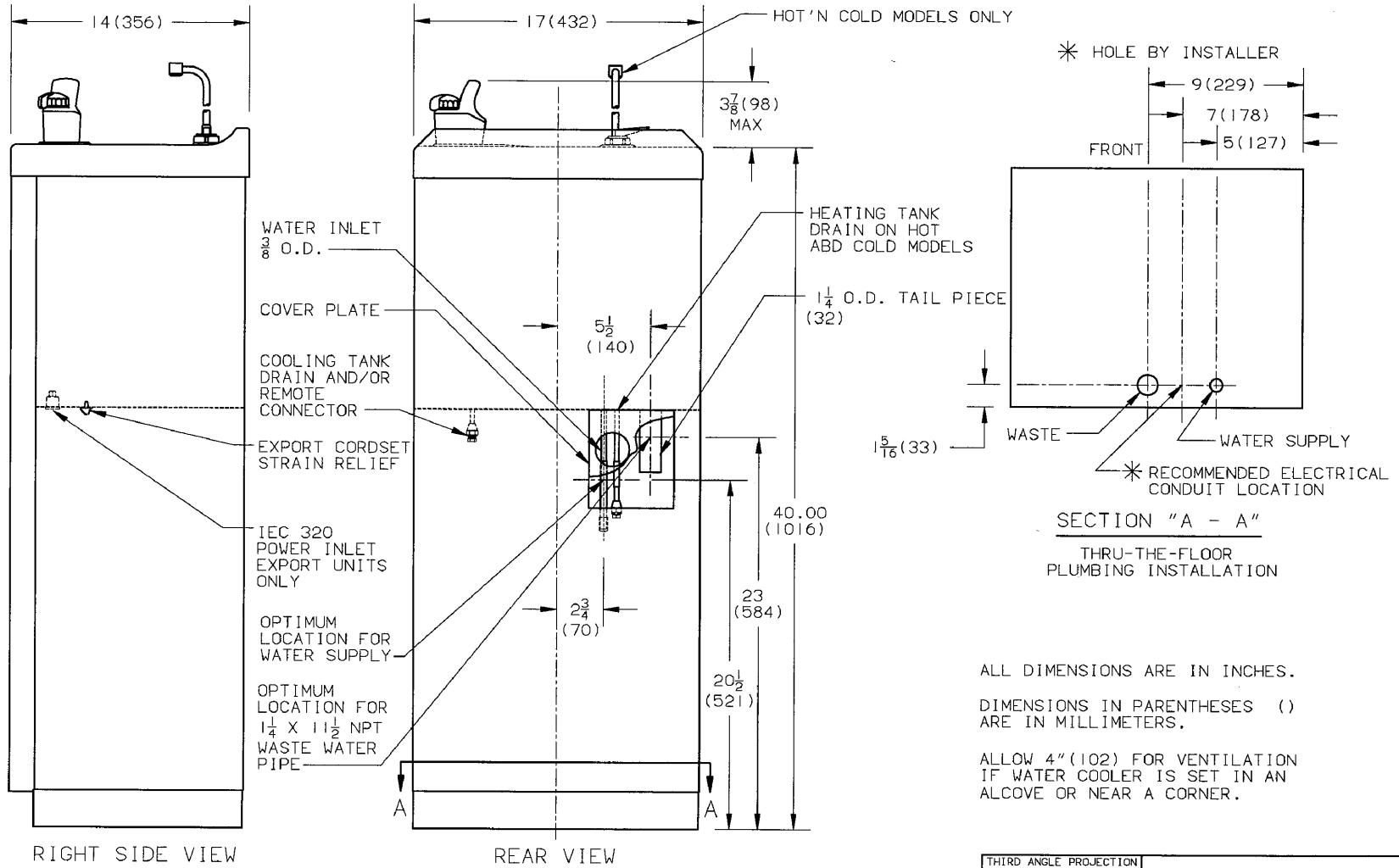

ALL DIMENSIONS ARE IN INCHES.  
 DIMENSIONS IN PARENTHESES ( )  
 ARE IN MILLIMETERS.  
 ALLOW 4" (102) FOR VENTILATION  
 IF WATER COOLER IS SET IN AN  
 ALCOVE OR NEAR A CORNER.

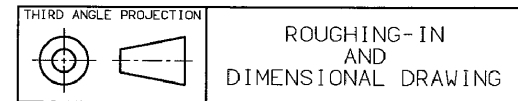

**Models PLF8FA, PLF8FAH, PLF14FA, and PLF14FAH**